

InLine™ + D

PART OF THE INLINE UV DISINFECTION SERIES

With automatic electric driven cleaning—sleeves and sensors remain deposit free.



One DVGW compliant sensor per lamp ensures accurate monitoring.



Robust electromagnetic ballasts that have a proven design life of 20 years, or electronic ballasts for additional energy savings.



MUNICIPAL DRINKING WATER DISINFECTION

CHEMICAL-FREE DISINFECTION IS HERE!

Water plants across North America are expanding to include UV equipment to treat chlorine resistant pathogens like Cryptosporidium, ensuring finished water is free from disinfection by-products.

The InLine+D Series from Aquionics is now fully compliant with USEPA and German DVGW guidelines and requires no action spectra correction factor. The product utilizes medium pressure lamps allowing for a small footprint and compact design.

With one of the largest validation envelopes available, the InLine+D Series can treat process water up to 14 MGD through a single unit and a UV-Transmittance range of 65% to 95%. With validation testing conducted with two different surrogate microbes, a robust sizing model is ensured. A detailed third-party test report is available.

The use of the calculated dose approach through advanced calibrated sensors for dose monitoring allows units to operate with increased energy efficiency, optimizing operation and maintenance costs. Process variables can be quickly monitored and adjusted at the HMI or remotely via data connections.



AQUIONICS
UV Delivered 

InLine™ + D

THE INLINE UV DISINFECTION SYSTEM

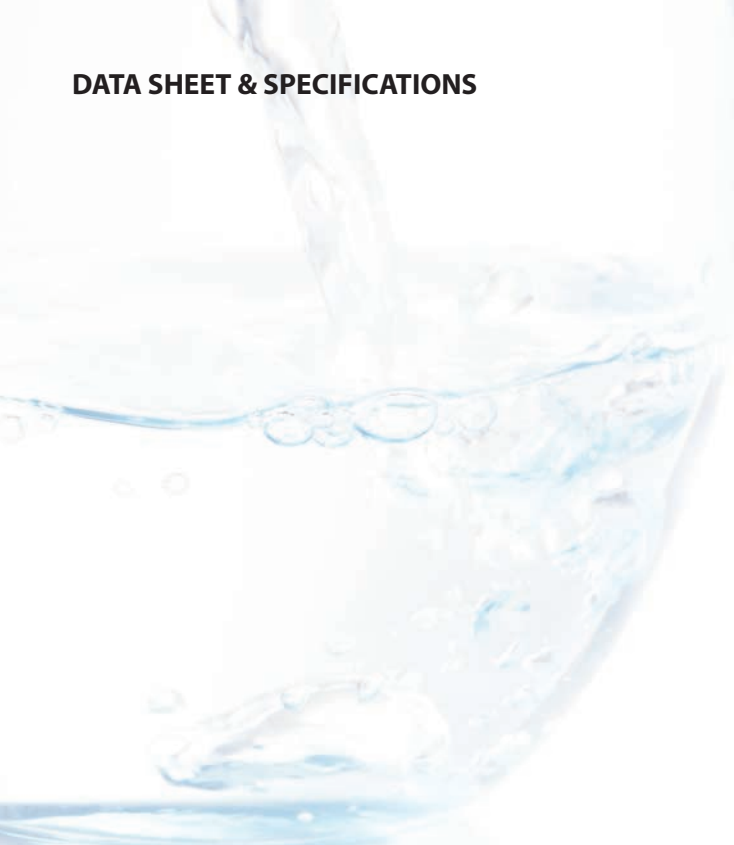

MUNICIPAL DRINKING WATER DISINFECTION

	InLine D450+	InLine D1000+	InLine D4000+	InLine D4500+	InLine D12000+	InLine D14000+
Flange (ANSI) inches	8	8	14	14	20	20
Number of Lamps	2	4	4	6	6	8
Max Power (kW)	6	10	16	24	36	48

Power Supply 480 Volt, 60 Hz, 3-Phase

InLine™ + D

- Validated to USEPA and DVGW Standards
- UV Validated Sensors (one per lamp)
- Automatic Cleaning with Chemical Option
- 8,000 Hour Lamp Life
- Standard 18 Month Warranty
- WQA Tested and Certified Against NSF/ANSI 61

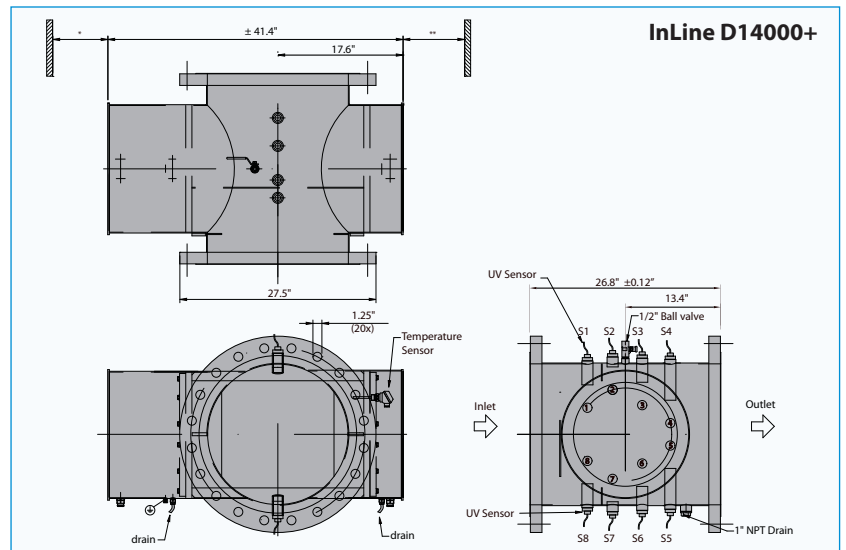

A HALMA COMPANY

Celebrating 80 Years of Pure Performance from the UV Technology Pioneers



1455 Jamike Ave. Ste. 100 | Erlanger, KY 41018 | P 859.341.0710 | T 800.925.0440 | F 859.341.0350 | WWW.AQUIONICS.COM

